

# HX75S



\* The sample may contain an optional configuration or painting style and design changes



Head Office(Sales Office)  
11F, GLOBAL R&D CENTER, 477 BUNDANG SUSEO-RO, BUNDANG-GU, SEONGNAM-SI, GYEONGGI-DO, 13553, KOREA

PLEASE CONTACT

Rated Power  
44.4kw / 2,100rpm

Operating Weight  
7,420kg

Bucket Capacity  
0.32m<sup>3</sup>



## New HX Series Excavators are Launched

### LATEST ENGINE TECHNOLOGY

- High performance, low fuel consumption yanmar engine
- Faster speed, More powerful performance

### SPACIOUS AND COMFORTABLE

- Good visibility, spacious cab
- Integrated Intelligent LCD cluster

### DURABLE AND RELIABLE

- High strength structural member, durable and reliable attachment
- High-quality hose

### SIMPLE AND CONVENIENT

- Convenient operation
- Centralized filter maintenance point



# ENHANCE CUSTOMER VALUE !

The HX series exceeds customer's expectation.



## ENVIRONMENTAL FRIENDLY, POWERFUL, FAST MACHINE WITH LOW FUEL CONSUMPTION

- Multiple engine fuel filtration system ensures engine and machine durability and performance.
- The optimized MCV design improves operating speed and productivity.
- The engine auto idle function reduces fuel cost.



## ADVANCED HYDRAULIC SYSTEM

- Load sensing system makes the machine smoother and faster.
- Parking brakes ensure more smoother rotation and easy control.



## DURABLE STRUCTURAL MEMBER

- Reinforced attachment
- Even in bad working conditions, the rack can withstand severe impact and pressure during the operation.
- X-type center and steel frame are optimized for better strength, excavators longer life.



## REDUCED ENGINE VIBRATION OPTIMIZED COOLING MODULE

- Improved engine mounting reduces cabin vibration
- Shock absorber durability increased
- Cooling module layout is greatly improved
- Convenient cooling module maintenance.



High-Performance  
Yanmar Engine



Grading Efficiency  
Improved



Reliable Bucket  
Pin Type



Reduced Noise,  
Improved Heat  
Dissipation



New Cluster



## BETTER PERFORMANCE, LESS COST



### Yanmar Engine 4TNV98-Z

Yanmar Engine, Output is 59.5HP/ 2,100 rpm,  
the maximum torque of 240.3N · m/ 1,575 rpm.

※ For best performance, engine should be operated at  
altitudes  
less than 1,200 m.

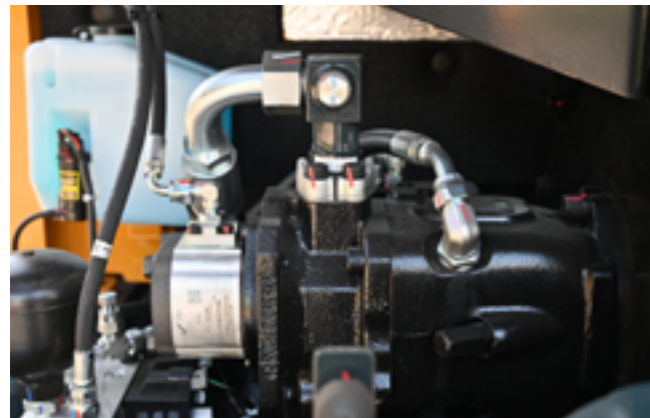

### Load Sensing System

The maximum flow rate of the main pump is  
158.4+17.6lpm. New load sensing system provide  
faster independent action a low fuel consumption.



The cooling fan diameter and number of blade  
(7 to 9) increased for better heat dissipation.



Standard LED Lamp

## FASTER AND MORE CONVENIENT MAINTENANCE



### Fully Open Hood

HX75S has fully open hood for convenient maintenance



Additional storage or grease gun



Fold-back air pre-filter



## Completely open engine hood

With completely open hood, maintenance is more convenient.



## Comfortable and safe operating space

In order to reduce the fatigue of the driver's performance, HX75S provides a comfortable operating environment for the pilot.



Better Rear Visibility



Improved Air Conditioning System



Ergonomic RCV

# SPECIFICATIONS



## ENGINE

<b>MODEL</b>	<b>4TNV98-Z</b>	
Type	Water cooled, 4 cycle diesel 4cylinders in line, direct injection, low emission	
SAE J1349	Gross	59.5HP (44.4kW) at 2,100 rpm
Horsepower	Net	59.5HP (44.2kW) at 2,150 rpm
Max. torque	24.2 kgf · m (175.0 lb · ft) at 1,575 rpm	
Bore X Stroke	98 mm (3.86") x 110 mm (4.33")	
Piston Displacement	3,319 cc (203 cu in)	
Batteries	1 x 12V x 100AH	
Starting Motor	12V-3.0kW	
Alternator	12V-100Amp	

## HYDRAULIC SYSTEM

<b>MAIN PUMP</b>	Variable displacement piston pumps	
Type	Variable displacement piston pumps	
Max. flow L/min	158L/min (41.7 US gpm / 34.8 UK gpm)	
System	Load sensing system	

<b>HYDRAULIC MOTORS</b>	Two speed axial piston motor with counter balance valve and parking brake	
Travel	Two speed axial piston motor with counter balance valve and parking brake	
Swing	Axial piston motor with automatic brake	

<b>RELIEF VALVE SETTING</b>	280 kgf/cm <sup>2</sup> (3,982 psi)	
Implement circuits	280 kgf/cm <sup>2</sup> (3,982 psi)	
Travel circuit	280 kgf/cm <sup>2</sup> (3,982 psi)	
Swing circuit	210 kgf/cm <sup>2</sup> (2,987 psi)	
Pilot circuit	35 kgf/cm <sup>2</sup> (498 psi)	
Service valve	Installed	

<b>HYDRAULIC CYLINDERS</b>	mm	
No. of cylinder bore X stroke	mm	
Boom	1-∅110×∅65×810	
Forearm	1-∅90×∅60×860	
Buckets	1-∅85×∅55×665	
Dozer	1-∅110×∅65×152	

## TRAVEL SYSTEM

Drive method	Full hydrostatic type
Drive motor	Axial piston motors
Reduction system	Planetary reduction gear
Max. travel speed	4.0 km/hr (2.5 mph) / 2.4 km/hr (1.5 mph)
Gradeability	35° (70%)
Parking brake	Multi-wet disc



## CONTROLS

Pilot pressure operated joysticks and pedals with detachable lever provide almost effortless and fatigueless operation.

Pilot control	Two joysticks with one safety lever (LH): Arm swing, Boom swing (RH): Boom and bucket (ISO)
Traveling and steering	Two levers with pedals
Engine throttle	Electric, Dial type



## SWING SYSTEM

Swing motor	Axial piston motor
Swing reduction	Planetary gear reduction
Swing bearing lubrication	Grease-bathed
Swing brake	Multi wet disc
Swing speed	10.9 rpm



## COOLANT AND OIL CAPACITY

(Refilling)	LITER	US gal	UK gal
Fuel tank	140.0	37.0	30.8
Engine coolant	11.0	2.9	2.4
Engine oil	9.2	2.4	2.0
Hydraulic tank	75.0	19.8	16.5
Hydraulic system	130.0	34.3	28.6



## UNDERCARRIAGE

X-leg type center frame is integrally welded with reinforced box-section track frames. The undercarriage includes lubricate rollers, track adjusters with shock absorbing springs and sprockets, and track chain with triple grouse shoes.

Center frame	X- leg type
Track frame	Pentagonal box type
Number of shoes	38 (each side)
Number of Carrier Rollers	1 (each side)
Number of track rollers	5 (each side)



## DIGGING FORCE (ISO)

Bucket digging force	5,700 kgf / 55.9 kN / 12,567 lbf
Arm digging force	4,477 kgf / 43.9 kN / 9,869 lbf



## WORKING EQUIPMENT

Standard equipment is including 3,700mm (12' 2") boom, 1,670mm (5' 6") arm, SAE haped 0.32 m<sup>3</sup> (0.42 yd<sup>3</sup>) digging bucket, lubricant, coolant, full fuel tank, hydraulic tank.

# DIMENSIONS & WORKING RANGE



unit: mm

F	Overall Length	6,080
G	Overall Width	2,260
H	Overall Height of Boom	2,690
I	Ground Clearance of Counterweight	755
J	Rear-End Length	1,730
K	Upperstructure Width	2,250
L	Overall Height of Cab	2,550

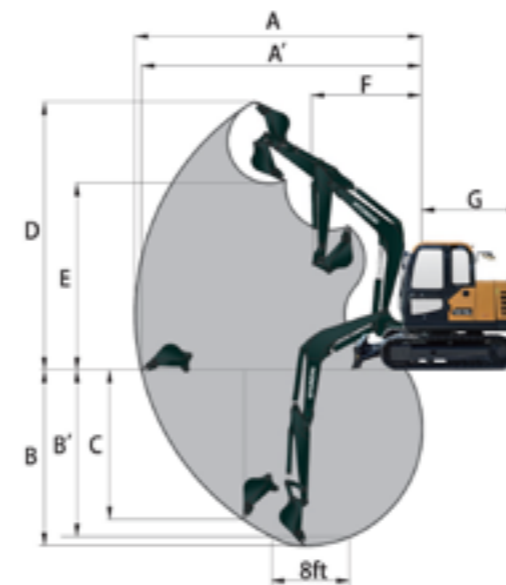

unit: mm

Boom length	3,700	
Arm length	1,670	
Bucket Capacity	0.32 m <sup>3</sup>	
A	Max. digging reach	6,335
A'	Max. digging reach on ground	6,185
B	Max. digging depth	4,015
B'	Max. digging depth (8ft level)	3,625
C	Max. vertical wall digging depth	3,120
D	Max. digging height	7,175
E	Max. dumping height	5,080
F	Min. swing radius	1,750