

# HX300S L

\* Photo may include optional equipment.



Head Office(Sales Office)  
11F, GLOBAL R&D CENTER, 477 BUNDANG SUSEO-RO, BUNDANG-GU, SEONGNAM-SI, GYEONGGI-DO, 13553, KOREA

PLEASE CONTACT

**Gross Power**  
194kW(260 HP) at 2,200 rpm

**Net Power**  
190kW(255 HP) at 2,200 rpm

**Bucket Capacity**  
1.27 m<sup>3</sup> (1.66 yd<sup>3</sup>)

**Operating Weight**  
30,200 kg / 66,580 lb

# WHAT'S NEWEST AND BEST

HX300SL

## THE BEST PRODUCTIVITY AND FUEL EFFICIENCY

- New Variable Power Control
- Fuel Rate Information **Option**
- Attachment Flow Control **Option**
- IPC (Intelligent Power Control) **Upgrade**
- ECO Gauge
- New Cooling System with Increased Air Flow
- Enlarged Air Inlet with Grill Cover

## ULTIMATE DURABILITY

- Durable Cooling Module
- Reinforced Pin, Bush, and Polymer Shim
- Reinforced Durability of Upper and Lower Structure and Attachments
- Wear Resistant Cover Plate
- Hi-grade (High-pressure) Hoses

## EASY CONTROL AND COMFORTABLE OPERATION

- Intelligent and Wide Cluster
- New Front Side Air-conditioning System
- Proportional Auxiliary Hydraulic System **Option**
- Quick Coupler Button **Option**
- New Audio System

## THE ULTIMATE SAFE ENVIRONMENT

- AAVM (Advanced Around View Monitoring) Camera System **Option**
- Hi MATAE (Remote Management System) **Option**
- Cab Suspension Mount
- Swing Lock System **Option**
- Fine Swing Control **Option**



\* Photo may include optional equipment.

# THE BEST PRODUCTIVITY AND FUEL EFFICIENCY

UP to 27%  
More fuel-efficient in leveling  
(Compared to 9S Series)

UP to 16%  
More fuel-efficient in truck loading  
(Compared to 9S Series)

UP to 9%  
Faster Truck loading  
(Compared to 9S Series)



\* Photo may include optional equipment.

## New Variable Power Control

The HX Series minimizes equipment input and output control signals to improve fuel efficiency. Its three-stage power mode ensures the highest performance in any operating environment.



\* **P(power) mode** : Maximizes speed and power of the equipment for heavy load work.



\* **S(standard) mode** : Optimizes performance and fuel efficiency of the equipment for general load work.



\* **E(economy) mode** : Improves the control system for light load work.

## Fuel Efficient System, Allows Great Performance

The HX Series has an eco-friendly, high-performance engine which ensures both excellent fuel efficiency and high power. With outstanding operating performance proven by rigorous tests at various work sites, it will satisfy any customer's needs.

15% increased greater screen from 7 to 8 inch is applied in HX Series.

More functions and better resolution are available with adding premium options.



Fuel Rate Information **Option**



## Eco Gauge

Eco gauge enables economic operation of machines. The gauge level and color displays engine torque and fuel efficiency level. On top of that, the status of fuel consumption such as average rate and the total amount of fuel consumed is displayed. Hourly and daily based fuel consumption can be checked in the detailed menu as well.



## IPC (Intelligent Power Control) Upgrade

HX Series adopts the upgraded IPC system. It is able to optimize pump flow rate and power at the various working condition through the individual pump control. Furthermore, optimized design of MCV and pipe line minimizes energy loss such as conflux and throttle loss.



## Attachment Flow Control **Option**

The HX Series improves pump flow rate by independent control of two pumps. It optimizes attachments for effective flow rate setting depending on attachments (ten breaker types and ten crusher types), enabling various operations matching the site environments.

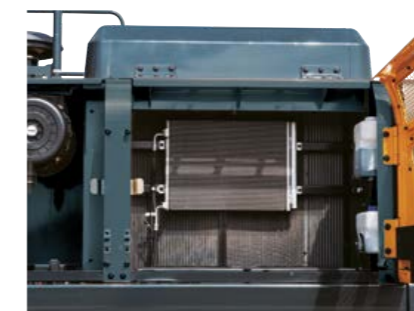

## New Cooling System with Increased Air Flow

With the cooling module improving air inflow, the HX Series provides excellent cooling performance by increasing heat dissipation.



## Enlarged Air Inlet with Grill Cover

Enlarged vent hole of the air inlet side cover and fine net grill to prevent penetration of foreign materials further improve durability.

# ULTIMATE DURABILITY

## New Exterior Design for Robustness and Safety

The true value of the HX Series lies in its durability. The robust frame structure and the attachments show the real value of the HX Series in tough working environments and promise higher productivity.

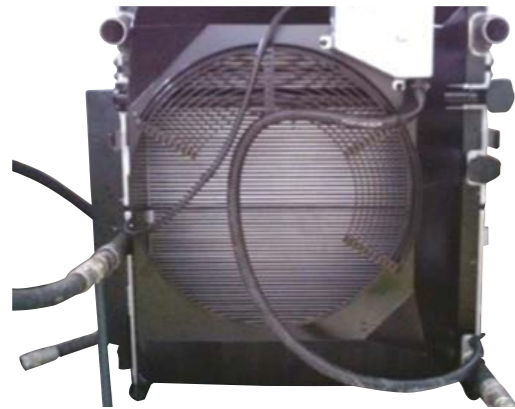

### ► Durable Cooling Module

The HX Series has a durable cooling module that passed stringent tests, demonstrating the highest productivity in tough working environments.



### ► Reinforced Pin, Bush, and Polymer Shim

The HX Series improves lubricity of connecting parts between the equipment and attachments. Gaps with attachments are minimized by wear-resistant long-life pins, bushes, and polymer shims, supporting the highest performance with invariable durability.

### Wear Resistant Cover Plate

A wear-resistant cover plate is installed at the end of the arm to minimize abrasion on the connector between the arm and the bucket. Vibration reduction of buckets enables more stable operation even in high-load work.



### ► Reinforced Durability of Upper and Lower Structure and Attachments

The upper and lower structure and attachments of the HX Series have higher durability than demanded on the site, as proven through numerous tests including road tests and virtual simulation. The wear resistance of the bucket has been improved by use of new material.

\* Photo may include optional equipment.



### Hi-grade (High-pressure) Hoses

The HX Series uses high-pressure hoses with improved heat and pressure resistance, greatly increasing the durability of the equipment.



# EASY CONTROL AND COMFORTABLE OPERATION

## Improved Instrument Panel for Easier Monitoring

Many electronic functions are concentrated in the most convenient spot for operators to improve work efficiency. The highly-advanced infotainment system, a product of HCE's intensive information technology development, enables both productivity and comfort while working! The HX Series is designed with the operator in mind.



### Intelligent and Wide Cluster

The 8-inch interactive touchscreen display of the HX Series is 15% larger than that of the previous model. The centralized switches on the display allow the operator to check the temperature outside the cab.



### New Front Side Air-conditioning System

The ventilation is designed for both warm and cool air reaching to operator's faces. It could help operators create more neat and enjoyable atmosphere through indoor air circulation.



### Proportional Auxiliary Hydraulic System **Option**

- Proportional control switch for better speed control
- Enlarge the operation convenience



### Front Side Air-Vent

### Quick Coupler Button **Option**

Easy attachment replacement of equipment is available with quick coupler button.

### New Audio System

The radio player with a USB-based MP3 player, an integrated Bluetooth hands-free feature, and a built-in microphone allow for phone calls while at work and in transit. The radio player is conveniently located on the right side of the operator to allow for improved access.



\* Photo may include optional equipment.

# THE ULTIMATE SAFE ENVIRONMENT

The true value of the HX Series lies in its durability. The robust frame structure and the attachments show the real value of the HX Series in tough working environments and promise higher productivity.



## AAVM (Advanced Around View Monitoring) Camera System Option

The HX Series has a state-of-the-art AAVM video camera system to secure field of vision for operators in all directions, thereby preventing accidents. Operators can easily check the workplace in the front and rear and to the right and left.

\*AVM (Around View Monitoring): Secure field of vision in all directions by nine views including 3D bird's eye view and 2D/4CH view.  
 \*IMOD (Intelligent Moving Object Detection): Inform when people or dangerous objects are detected within the range of operation (Recognition distance: 5m).

## HiMATE Option

### It's Convenient, Easy and Valuable

Hi MATE Hyundai's newly developed remote management system, utilizes GPS-satellite technology to provide customers with the highest level of service and product support available. Hi MATE enables users to remotely evaluate machine performance, access diagnostic information, and verify machine locations at the touch of a button.

#### What is benefits



#### Increase Productivity

It helps you operate machines in efficient. You can check the difference between total engine hours and actual working hours. See how productive your machines are and plan any required cost saving solutions. Hi MATE offers working information such as working / idling hours, fuel consumption and rate.



#### Convenient and Easy Monitoring

There is nothing much to do to monitor your machines. Just log on to the Hi MATE website or mobile application. Hi MATE allows you to watch your machines whenever and wherever you are.



#### Security

Protect your machines from theft or unauthorized usage with Hi MATE. If the machine moves out of the Geo-fence boundary, you will get alerts.



\* Photo may include optional equipment.

#### Cab Suspension Mount

With a low-vibration design by the coil spring and damper inside the mount, the cab suspension mount of the HX Series reduces noise inside the cabin and improves durability, providing a comfortable operation space that lessens operators' fatigue.

#### Swing Lock System Option

Swing lock system is provided to maintain stability when swing movement needs to be limited, improving operating speed and productivity.

#### Fine Swing Control Option

Fine swing control is available for customer's convenience when users want to control fine swing.

# HX300SL SPECIFICATIONS

## ENGINE

Maker / Model	HYUNDAI / HM8.3
Type	6 cylinder, water cooled, 4-cycle, turbocharged, charge air cooled, direct injection, mechanical controlled diesel engine.
Engine Power	194 kW (260 HP) at 2,200 rpm
Net Power	190 kW (255 HP) at 2,200 rpm
Max. Power	195 kW (261 HP) at 2,000 rpm
Peak Torque	1,150 N · m (848 lb.ft) at 1,300 rpm
Displacement	8.3 l (506 cu in)

## HYDRAULIC SYSTEM

<b>MAIN PUMP</b>	
Type	Variable displacement tandem axis piston pumps
Max. flow	2 × 285 lpm
Sub-pump for pilot circuit	Gear pump

Cross-sensing and fuel saving pump system.

## HYDRAULIC MOTORS

Travel	Two speed axial pistons motor with brake valve and parking brake
Swing	Axial piston motor with automatic brake

## RELIEF VALVE SETTING

Implement circuits	350 kgf/cm <sup>2</sup> (4,980 psi)
Travel	350 kgf/cm <sup>2</sup> (4,980 psi)
Power boost (boom, arm, bucket)	380 kgf/cm <sup>2</sup> (5,400 psi)
Swing circuit	300 kgf/cm <sup>2</sup> (4,270 psi)
Pilot circuit	40 kgf/cm <sup>2</sup> (570 psi)
Service valve	Installed

## HYDRAULIC CYLINDERS

No. of cylinder bore × stroke	Boom-2 ∅140 x 1,465mm Arm ∅150 x 1,670mm Bucket ∅135 x 1,150mm
-------------------------------	--

## DRIVES & BRAKES

Drive method	Fully hydrostatic type
Drive motor	Axial piston motor, in-shoe design
Reduction system	Planetary reduction gear
Max. drawbar pull	27,400 kgf (60,410 lbf)
Max. travel speed (high / low)	6.1 km/hr (3.8 mph) / 3.4 km/hr (2.1 mph)
Gradeability	35° (70%)
Parking brake	Multi wet disc

## CONTROL

Pilot pressure operated joysticks and pedals with detachable lever provide almost effortless and fatigueless operation.

Pilot control	Two joysticks with one safety lever (LH) : Swing and arm, (RH) : Boom and bucket (ISO)
Traveling and steering	Two levers with pedals
Engine throttle	Electric, dial type

## SWING SYSTEM

Swing motor	Fixed displacement axial piston motor
Swing reduction	Planetary gear reduction
Swing bearing lubrication	Grease-bathed
Swing brake	Multi wet disc
Swing speed	12.2 rpm

## COOLANT & LUBRICANT CAPACITY

	liter	US gal	UK gal
Fuel tank	500	132.1	110.0
Engine coolant	25	6.6	5.5
Engine oil	26.5	7.0	5.8
Swing device	11	2.91	2.42
Final drive (each)	8.0 (7.8)	2.06	1.72
Hydraulic system (including tank)	330	87.2	72.6
Hydraulic tank	190	50.2	41.8

## UNDERCARRIAGE

The X-leg type center frame is integrally welded with reinforced box-section track frames. The undercarriage includes lubricated rollers, idlers, track adjusters with shock absorbing springs and sprockets, and a track chain with double or triple grouser shoes.

Center frame	X - leg type
Track frame	Pentagonal box type
No. of shoes on each side	48 EA
No. of carrier roller on each side	2 EA
No. of track roller on each side	9 EA
No. of rail guard on each side	2 EA

## OPERATING WEIGHT (APPROXIMATE)

Operating weight, including 6,245 mm (20' 6") boom, 3,100 mm (10' 2") arm, SAE heaped 1.27 m<sup>3</sup> (1.66 yd<sup>3</sup>) bucket, lubricant, coolant, full fuel tank, full hydraulic tank, and all standard equipments.

## OPERATING WEIGHT

Shoes		Operating weight		Ground pressure
Type	Width mm (in)	kg (lb)		kgf/cm <sup>2</sup> (psi)
Triple grouser	600 (24")	HX300SL	30,200 (66,580)	0.58 (8.27)
		HX300SHW	32,490 (71,630)	0.63 (8.89)
	700 (28")	HX300SL	30,770 (67,840)	0.51 (7.22)
		HX300SHW	33,060 (72,880)	0.55 (7.76)
800 (32")	HX300SL	31,150 (68,670)	0.45 (6.40)	
	HX300SLR	33,910 (74,760)	0.49 (6.96)	
	HX300SHW	33,440 (73,720)	0.48 (6.87)	
Double grouser	700 (28")	HX300SHW	34,000 (74,960)	0.56 (7.96)





## AIR CONDITIONING SYSTEM

The air condition system for the machine contains the fluorinated greenhouse gas with global warming potential of R134a. (Global Warming Potential : 1,430) The system hold 0.8 kg refrigerant consisting of a CO<sub>2</sub> equivalent 1.14 kg metric tonne. For more information, Please refer to the manual.

# HX300SL BUCKET SELECTION GUIDE & DIGGING FORCE

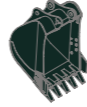
## BUCKETS

All buckets are welded with high-strength steel.

					
SAE heaped m <sup>3</sup> (yd <sup>3</sup> )	○ 1.27 (1.66) ○ 1.51 (1.98) ○ 1.75 (2.29) ○ 1.85 (2.42)	◆ 1.23 (1.61) ◆ 1.47 (1.92)	◆ 1.20 (1.57) ◆ 1.45 (1.90)	◆ 1.57 (2.05)	★ 0.52 (0.68)

SAE heaped	CECE heaped	Capacity m <sup>3</sup> (yd <sup>3</sup> )		Width mm (in)		Weight kg (lb)	Tooth EA	Recommendation mm (ft.in)					
		Without side cutters	With side cutters	6,245 (20' 6") Boom					10,200 (33' 6") Boom				
				2,100 (6' 11") Arm	2,500 (8' 2") Arm			2,850 (9' 4") Arm		3,100 (10' 2") Arm	3,750 (12' 4") Arm	7,850 (25' 9") Arm	
○ 1.27 (1.66)	1.10 (1.44)	1,280 (50.4")	1,440 (56.7")	1,090 (2,400)	5	●	●	●	●	●	-		
○ 1.51 (1.98)	1.30 (1.70)	1,490 (58.7")	1,650 (65.0")	1,215 (2,680)	6	●	●	●	■	▲	-		
○ 1.75 (2.29)	1.50 (1.96)	1,700 (66.9")	1,860 (73.2")	1,315 (2,900)	6	●	■	■	▲	▲	-		
○ 1.85 (2.42)	1.61 (2.11)	1,590 (62.6")	1,785 (70.3")	1,325 (2,920)	6	■	■	▲	▲	×	-		
◆ 1.23 (1.61)	1.10 (1.44)	1,205 (47.4")	1,260 (49.6")	1,085 (2,390)	5	●	●	●	●	●	-		
◆ 1.47 (1.92)	1.32 (1.73)	1,405 (55.3")	1,460 (57.5")	1,185 (2,610)	5	●	●	●	■	■	-		
◆ 1.20 (1.57)	1.08 (1.41)	1,180 (46.5")	1,240 (48.8")	1,380 (3,040)	5	●	●	●	●	-	-		
◆ 1.45 (1.90)	1.29 (1.69)	1,380 (54.3")	1,440 (56.7")	1,505 (3,320)	5	●	●	■	■	-	-		
◆ 1.57 (2.05)	1.40 (1.83)	1,480 (58.3")	1,540 (60.6")	1,565 (3,450)	5	●	■	■	■	-	-		
★ 0.52 (0.68)	0.45 (0.59)	870 (34.3")	1,020 (40.2")	455 (1,000)	5	-	-	-	-	-	●		

- General Purpose
- ◆ Heavy duty bucket
- ◆ Rock-Heavy duty bucket
- ★ Long reach bucket

- : Applicable for materials with density of 2,100 kg/m<sup>3</sup> (3,500 lb/yd<sup>3</sup>) or less
- : Applicable for materials with density of 1,800 kg/m<sup>3</sup> (3,000 lb/yd<sup>3</sup>) or less
- : Applicable for materials with density of 1,500 kg/m<sup>3</sup> (2,500 lb/yd<sup>3</sup>) or less
- ▲ : Applicable for materials with density of 1,200 kg/m<sup>3</sup> (2,000 lb/yd<sup>3</sup>) or less
- : Not Recommended

## ATTACHMENT

Booms and arms are of all-welded, low-stress, full-box section design. 6,245 mm (20' 6"), 10,200 mm (33' 6") Booms and 2,100 mm (6' 11"), 2,500 mm (8' 2"), 2,850 mm (9' 4"), 3,100mm (10' 2"), 3,750mm (12' 4"), 7,850 mm (25' 9") Arms are available, Hyundai Bucket are all-welded, high-strength steel implements.

## DIGGING FORCE

Boom	Length	mm (ft.in)	6,245 (20' 6")				10,200 (33' 6")	Remark
			Weight		kg (lb)		kg (lb)	
Arm	Length	mm (ft.in)	2,100 (6' 11")		2,500 (8' 2")		3,100 (10' 2")	
			Weight		kg (lb)		kg (lb)	
Bucket Digging Force	SAE	mm (ft.in)	2,100 (6' 11")		2,500 (8' 2")		3,100 (10' 2")	[ ] : Power Boost
			Weight		kg (lb)		kg (lb)	
			kN		kgf		lbf	
	ISO	mm (ft.in)	2,100 (6' 11")		2,500 (8' 2")		3,100 (10' 2")	
			Weight		kg (lb)		kg (lb)	
			kN		kgf		lbf	

Note : Boom weight includes arm cylinder, piping, and pin  
Arm weight includes bucket cylinder, linkage, and pin

# HX300SL DIMENSIONS & WORKING RANGE

## HX300S L DIMENSIONS

6.245 m (20' 6"), 10.2 m (33' 6") BOOM and 2.1 m (6' 11"), 2.5 m (8' 2"), 3.10 m (10' 2"), 3.75 m (12' 4"), 7.85m (25' 9") ARM

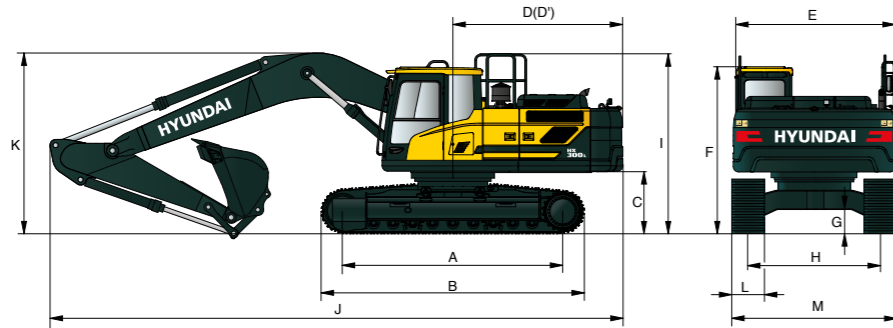

Unit : mm (ft-in)

A Tumbler distance	4,040 (13' 3")	Boom length					6,245 (20' 6")	10,200 (33' 6")			
*B Overall length of crawler	4,946 (16' 2")	Arm length					2,100 (6' 11")	2,500 (8' 2")	3,050 (10' 0")	3,750 (12' 4")	7,850 (25' 9")
*C Ground clearance of counterweight	1,180 (3' 10")	J Overall length					10,710 (35' 2")	10,670 (35' 0")	10,560 (34' 8")	10,630 (34' 11")	14,750 (48' 5")
D Tail swing radius	3,345 (11' 0")	*K Overall height of boom					3,580 (11' 9")	3,485 (11' 5")	3,335 (10' 11")	3,535 (11' 7")	3,560 (11' 8")
D' Rear-end length	3,265 (10' 9")	L Track shoe Width					600 (24")	700 (28")	800 (32")		
E Overall width of upperstructure	2,980 (9' 9")	M Overall Width					3,200 (10' 6")	3,300 (10' 10")	3,400 (11' 2")		
*F Overall height of cab	3,125 (10' 3")										
G Min. ground clearance	500 (1' 8")										
H Track gauge	2,600 (8' 6")										
*I Overall height of guardrail (Opt)	3,330 (10' 11")										

\* This figure includes the size of grouser.

## HX300S L WORKING RANGE

Unit : mm (ft-in)

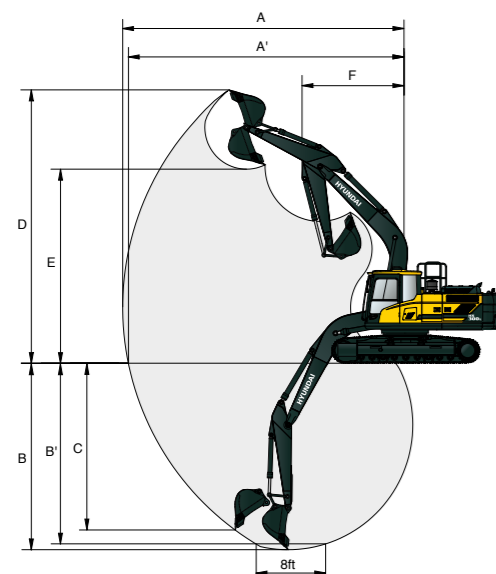

Boom length	6,245 (20' 6")					10,200 (33' 6")
Arm length	2,100 (6' 11")	2,500 (8' 2")	3,100 (10' 2")	3,750 (12' 4")	7,850 (25' 9")	
A Max. digging reach	9,945 (32' 8")	10,255 (33' 8")	10,815 (35' 6")	11,345 (37' 3")	18,530 (60' 10")	
A' Max. digging reach on ground	9,720 (31' 11")	10,035 (32' 11")	10,610 (34' 10")	11,145 (36' 7")	18,410 (60' 5")	
B Max. digging depth	6,225 (20' 5")	6,625 (21' 9")	7,225 (23' 8")	7,880 (25' 10")	14,740 (48' 4")	
B' Max. digging depth (8' level)	6,000 (19' 8")	6,410 (21' 0")	7,045 (23' 1")	7,705 (25' 3")	14,660 (48' 1")	
C Max. vertical wall digging depth	5,715 (18' 9")	6,135 (20' 2")	6,725 (22' 1")	7,305 (24' 0")	13,700 (44' 11")	
D Max. digging height	10,080 (33' 1")	10,100 (33' 2")	10,405 (34' 2")	10,485 (34' 5")	14,590 (47' 10")	
E Max. dumping height	6,975 (22' 11")	7,040 (23' 1")	7,335 (24' 1")	7,450 (24' 5")	12,270 (40' 3")	
F Min. swing radius	4,185 (13' 9")	3,780 (12' 5")	4,095 (13' 5")	4,150 (13' 7")	6,270 (20' 7")	

## HX300S HW DIMENSIONS

6.245 m (20' 6") BOOM and 2.1 m (6' 11"), 2.5 m (8' 2"), 3.10 m (10' 2"), 3.75 m (12' 4") ARM

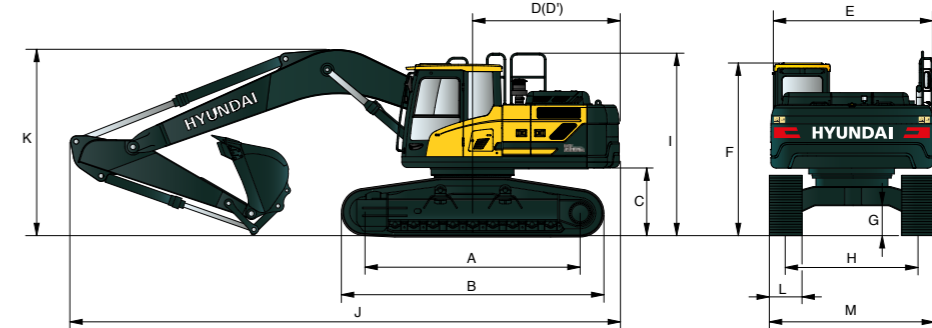

Unit : mm (ft-in)

A Tumbler distance	4,030 (13' 3")	Boom length					6,245 (20' 6")				
*B Overall length of crawler	5,010 (16' 5")	Arm length					2,100 (6' 11")	2,500 (8' 2")	3,100 (10' 2")	3,750 (12' 4")	
*C Ground clearance of counterweight	1,490 (4' 11")	J Overall length					10,680 (35' 0")	10,595 (34' 9")	10,410 (34' 2")	10,510 (34' 6")	
D Tail swing radius	3,345 (11' 0")	*K Overall height of boom					3,715 (12' 2")	3,590 (11' 9")	3,385 (11' 1")	3,520 (11' 7")	
D' Rear-end length	3,265 (10' 9")	L Track shoe Width					600 (24")	700 (28")	800 (32")		
E Overall width of upperstructure	2,980 (9' 9")	M Overall Width					3,470 (11' 5")	3,570 (11' 9")	3,670 (12' 0")		
*F Overall height of cab	3,435 (11' 3")										
G Min. ground clearance	765 (2' 6")										
H Track gauge	2,870 (9' 5")										
*I Overall height of guardrail	3,650 (12' 0")										

\* This figure includes the size of grouser.

## HX300S HW WORKING RANGE

Unit : mm (ft-in)

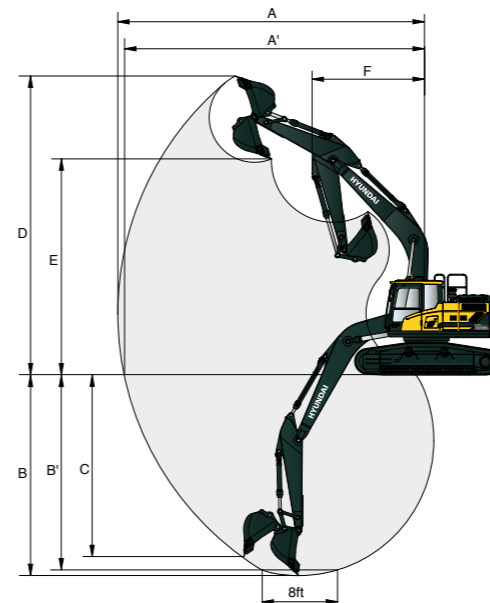

Boom length	6,245 (20' 6")				
Arm length	2,100 (6' 11")	2,500 (8' 2")	3,100 (10' 2")	3,750 (12' 4")	
A Max. digging reach	9,945 (32' 8")	10,255 (33' 8")	10,815 (35' 6")	11,345 (37' 3")	
A' Max. digging reach on ground	9,635 (31' 7")	9,955 (32' 8")	10,535 (34' 7")	11,075 (36' 4")	
B Max. digging depth	5,880 (19' 3")	6,285 (20' 7")	6,885 (22' 7")	7,535 (24' 9")	
B' Max. digging depth (8' level)	5,660 (18' 7")	6,070 (19' 11")	6,705 (22' 0")	7,360 (24' 2")	
C Max. vertical wall digging depth	5,370 (17' 7")	5,795 (19' 0")	6,385 (20' 11")	6,965 (22' 10")	
D Max. digging height	10,420 (34' 2")	10,440 (34' 3")	10,745 (35' 3")	10,825 (35' 6")	
E Max. dumping height	7,315 (24' 0")	7,380 (24' 3")	7,675 (25' 2")	7,790 (25' 7")	
F Min. swing radius	4,185 (13' 9")	3,780 (12' 5")	4,095 (13' 5")	4,150 (13' 7")	





# HX300SL LIFTING CAPACITY

Rating over-front Rating over-side or 360 degree

## HX300SLR

10.2 m (33' 6") boom, 7.85 m (25' 9") arm equipped with 800 mm (31") triple grouser shoe and 7,000 kg counter weight.

Lift point height m (ft)	Lift radius														At max. reach												
	1.5m (4.9ft)	3.0m (9.8ft)	4.5m (14.8ft)	6.0m (19.7ft)	7.5m (24.6ft)	9.0m (29.5ft)	10.5m (34.4ft)	12.0m (39.4ft)	13.5m (44.3ft)	15.0m (49.2ft)	16.5m (54.1ft)	Capacity	Reach	m (ft)													
13.5m kg 44.3ft lb												*750	*750	12.91													
12.0m kg 39.4ft lb									*1,000	*1,000		*690	*690	14.11													
10.5m kg 34.4ft lb									*2,200	*2,200		*1,520	*1,520	(46.3)													
9.0m kg 29.5ft lb									*1,300	*1,300	*700	*700	*660	*660	15.06												
7.5m kg 24.6ft lb									*2,870	*2,870	*1,540	*1,540	*1,460	*1,460	(49.4)												
6.0m kg 19.7ft lb									*1,480	*1,480	*1,090	*1,090	*650	*650	15.82												
4.5m kg 14.8ft lb									*3,260	*3,260	*2,400	*2,400	*1,430	*1,430	(51.9)												
3.0m kg 9.8ft lb									*1,650	*1,650	*1,340	*1,340	*640	*640	16.40												
1.5m kg 4.9ft lb									*3,640	*3,640	*2,950	*2,950	*1,410	*1,410	(53.8)												
0.0m kg 0.0ft lb																											
-1.5m kg -4.9ft lb	*1,280	*1,280	*1,770	*1,770	*3,090	*3,090	*5,900	*5,900	*6,890	4,920	*5,520	3,870	*4,630	3,130	*4,010	2,570	*3,570	2,140	*2,610	1,790	*1,320	*1,320	*890	*890	16.90		
-3.0m kg -9.8ft lb	*2,820	*2,820	*3,900	*3,900	*6,810	*6,810	*13,010	*13,010	*15,190	10,850	*12,170	8,530	*10,210	6,900	*8,840	5,670	*7,870	4,720	*5,750	3,950	*2,910	*2,910	*1,960	*1,960	(55.4)		
-4.5m kg -14.8ft lb	*5,670	*5,670	*6,830	*6,830	*9,240	*9,240	*13,910	13,730	*16,760	10,100	13,470	7,870	10,870	6,370	9,020	5,270	7,650	4,430	*5,270	3,770					*2,510	*2,510	(52.3)
-6.0m kg -19.7ft lb	*3,270	*3,270	*3,860	*3,860	*5,000	*5,000	*7,130	6,220	*7,700	4,530	6,060	3,520	4,880	2,840	4,060	2,360	3,450	1,990	*1,720	1,710					*1,340	*1,340	15.24
-7.5m kg -24.6ft lb	*4,020	*4,020	*4,710	*4,710	*5,970	*5,970	*8,300	6,290	*7,620	4,560	6,070	3,530	4,890	2,850	4,070	2,360	*3,260	2,010							*1,630	*1,630	14.33
-9.0m kg -29.5ft lb	*4,850	*4,850	*5,690	*5,690	*7,170	*7,170	*9,220	6,440	*7,350	4,650	*6,040	3,600	4,950	2,900	4,130	2,420									*2,100	*2,100	13.19
-10.5m kg -34.4ft lb	*5,790	*5,790	*6,860	*6,860	*8,720	*8,720	*8,490	6,660	*6,820	4,810	*5,610	3,730	*4,650	3,020											*2,960	2,630	11.74
-12.0m kg -39.4ft lb	*8,320	*8,320	*9,440	*9,440	*7,340	6,990	*5,900	5,070	*4,770	3,950															*4,190	3,520	9.85

- Lifting capacity are based on ISO 10567.
- Lifting capacity of the Robex Series does not exceed 75% of tipping load with the machine on firm, level ground or 87% of full hydraulic capacity.
- The Lift-point is bucket pivot mounting pin on the arm (without bucket mass).
- (\*) indicates load limited by hydraulic capacity.

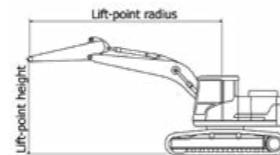

# HX300SL STANDARD / OPTION

ENGINE		
Hyundai HM8.3 Engine		●
HYDRAULIC SYSTEM		
Intelligent Power Control (IPC)		
3-power mode, 2-work mode, user mode		●
Variable power control		●
Pump flow control		●
Attachment mode flow control		○
Engine auto idle		●
Engine auto shutdown control		○
CAB & INTERIOR		
ISO Standard Cabin		
Rise-up type windshield wiper		●
Radio / USB player		●
Handsfree mobile phone system with USB		●
12 V power outlet (24 V DC to 12 V DC converter)		●
Electric horn		●
All-weather steel cab with 360° visibility		●
Safety glass windows		●
Sliding fold-in front window		●
Sliding side window (LH)		●
Lockable door		●
Hot & Cool box		●
Storage compartment & Ashtray		●
Sun visor		●
Door and cab locks, one key		●
Pilot-operated slidable joystick		●
Cabin lights		○
Cabin front window rain guard		○
Cabin roof-steel cover		●
Automatic Climate Control		
Air conditioner & Heater		●
Defroster		●
Starting aid (air grid heater) for cold weather		●
Centralized Monitoring		
8" LCD display - Normal type		●
8" LCD display - Premium type		○
Engine speed or trip meter / Accel		●
Engine coolant temperature gauge		●
Max power		●
Low speed / High speed		●
Auto idle		●
Overload warning with alarm		○
Check engine		●
Air cleaner clogging		●
Indicators		●
ECO gauges		●
Fuel level gauge		●
Hyd. oil temperature gauge		●
Warnings		●
Communication error		●
Low battery		●
Clock		●
Seat		
Mechanical suspension without heater		●
Mechanical suspension with heater		○
Adjustable air suspension without heater		○
Adjustable air suspension with heater		○
Cabin FOPS/FOG		
FOPS (Falling object protective structures) ISO 10262 Level 2		○
FOG (Falling object guard) ISO/DIS 10262 Level 2	Front & Tops guard	○
	Top guard	○
Cabin ROPS		
ROPS (Roll over protective structures) - ISO 12117-2		○

SAFETY		
Battery master switch		●
Rearview camera		○
AAVM (Advanced around view monitoring)		○
Four front working lights (2 boom mounted, 2 front frame mounted)		●
Travel alarm		●
Rear work lamp		○
Beacon lamp		○
Automatic swing brake		●
Boom holding system		●
Arm holding system		●
Safety lock valve for boom cylinder with overload warning device		○
Safety lock valve for arm cylinder		○
Swing Lock system		○
Two outside rearview mirror		●
ATTACHMENT		
Booms		
6.245 m, 20' 6" Mono		●
6.245 m, 20' 6" Mono (HD)		-
10.20 m, 33' 6" Long Reach		○
Arms		
2.10 m, 6' 11"		○
2.5 m, 8' 2"		○
3.10 m, 10' 2"		●
3.10 m, 10' 2" (HD)		-
3.75 m, 12' 4"		○
7.85 m, 25' 9" Long Reach		○
OTHERS		
Removable clean-out dust net for cooler		●
Removable washer tank		●
Fuel pre-filter		●
Fuel warmer		○
Self-diagnostics system		●
HiMATE (Remote management system)		○
Batteries (2 × 12 V × 150 AH)		●
Fuel filler pump (50 lpm)		○
Single-acting piping kit (Breaker, etc.)		○
Double-acting piping kit (Clamshell, etc.)		○
Rotating piping kit		○
Quick coupler piping		○
Quick coupler		○
Accumulator for lowering work equipment		●
Pattern change valve (4 patterns)		○
Fine swing control system		○
General type guardrail		○
Tool kit		○
UNDERCARRIAGE		
Lower frame under cover (Additional)		●
Lower frame under cover (Normal)		●
Track Shoes		
Double grouser shoe (700 mm, 28")		○
Triple grouser shoe (600 mm, 24")		●
Triple grouser shoe (700 mm, 28")		●
Triple grouser shoe (800 mm, 32")		●

● : Standard  
○ : Option  
- : Not available

\* Standard and optional equipment may vary. Contact your Hyundai dealer for more information.  
The machine may vary according to international standards.  
\* The photos may include attachments and optional equipment that are not available in your area.  
\* Materials and specifications are subject to change without advance notice.  
\* All imperial measurements rounded off to the nearest pound or inch.